



GROUP 31 QUICK REFERENCE GUIDE

Sell the right battery for the application!

SUPER START	HEAVY & MEDIUM DUTY TRUCK (Class 6, 7 & 8) QUICK REFERENCE BATTERY APPLICATION CHART
SLEEPER CAB	Minimum of four (4) DUAL PURPOSE BATTERIES with a low voltage disconnect or battery management system. 31HD, 31HDT, AGM31DT
DAY CAB LINE HAUL	STARTING BATTERY with the number of batteries determined by the CCA capacity. 31-4, 31-4T, 31-5, 31-5T, AGM31T, AGM31DT
DAY CAB DELIVERY*	DUAL PURPOSE BATTERIES with the number of batteries per truck determined by the engine CCA requirement. 31HD, 31HDT, AGM31T, AGM31DT
PACKAGE & DELIVERY*	DUAL PURPOSE BATTERIES with the number of batteries per truck determined by the engine CCA requirement. 31HD, 31HDT, AGM31DT
REEFER	DUAL PURPOSE BATTERY 31HD, 31HDT, AGM31T, AGM31DT
HVAC UNITS LIFT GATES APU SYSTEM	DEEP CYCLE PERFORMANCE AGM31DT

* Over 20 stops a day, use the 31HD, 31HDT or AGM31DT.

GROUP 31 COMPARISON

SUPER START	CCA @ 0°F	RES. CAP. @ 80°F	AC DELCO ACD LINE	AC DELCO PROFESSIONAL	EXIDE	CHAMPION	INTERSTATE	POWERSVOLT
DUAL PURPOSE								
31HD	730	190	—	—	—	—	31P-ECL	—
31HDT	730	190	—	—	—	—	31-ECL	—
AGM31DT	800	—	—	—	RF-31	—	—	—
AGM31T	925	—	—	—	XRF-31D	—	SC31DS	—
STARTING								
31-4	760	170	—	1111 1201	— COM-31E	—	31P-LHD 31P-VHD	VMF31P-5 V31P-5
31-4T	760	170	ACD1109C ACD1149C	1110 1200	— COM-31D	PX31750C —	31-LHD 31-VHD	VMF31S-5 V31S-5
31-5	950	175	ACD31TP —	31-901CT —	HP-31E XHP-31E	PX31925A —	31P-MHD —	VMF31P-7 V31P-7G
31-5T	950	175	ACD31TS —	31-900CT —	HP-31D XHP-31D	PX31925C —	31-MHD —	VMF31S-7 V31S-7G

Dual Purpose Cycling/Starting

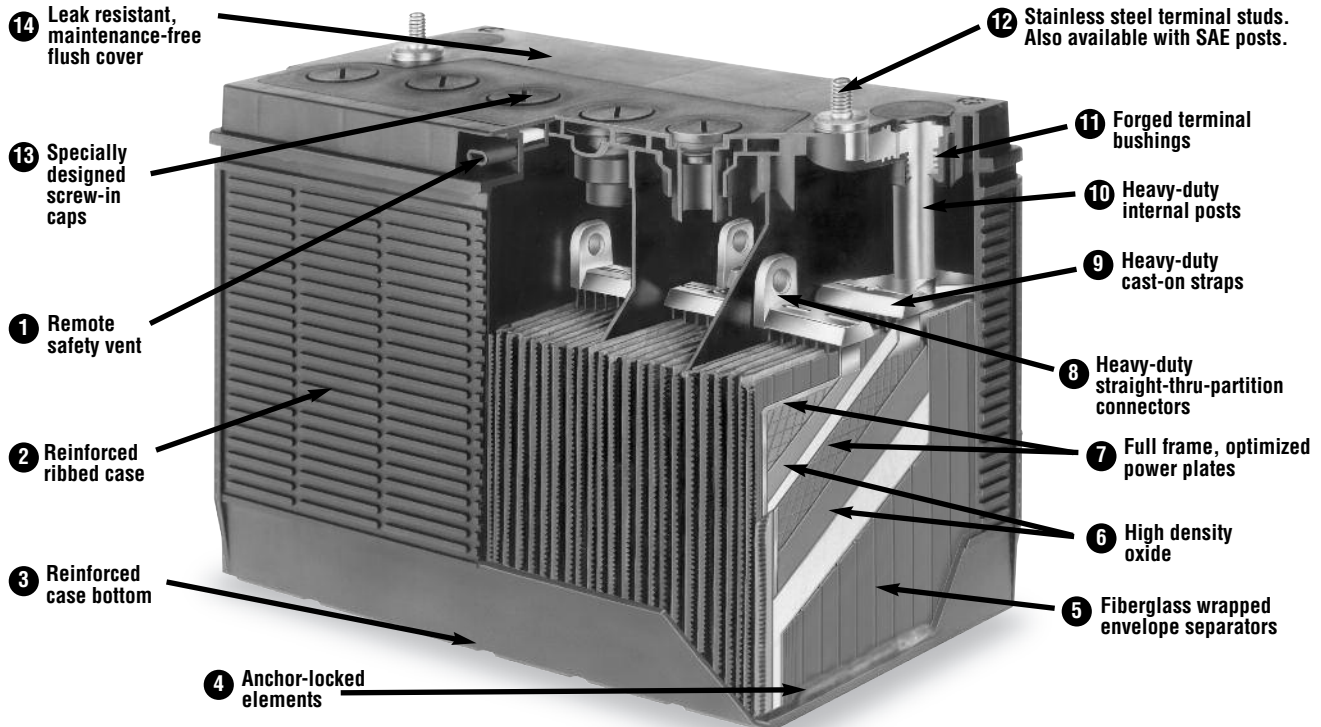

AGM Maintenance-Free Construction

1. Convenient Handle — maximizes ease of transport and installation

2. Stainless Steel Studs — (SAE post available) resists life-robbing corrosion

3. Safety Relief Valve System — prevents capacity loss and controls pressure

4. Fortified Posts, Straps, and Welds — resist vibration damage, maximize current transfer

5. Heavy-Duty Optimized Power Plates — optimize battery's power and energy storage capacity

6. Enhanced Electrolyte Suspension System — completely absorbs electrolyte for spillproof design

7. Optimized Component Compression — provides superior vibration resistance

—**Ultra-Pure Demineralized Electrolyte** — delivers true maintenance-free performance

